

1 Ground Floor Plan 1 : 100

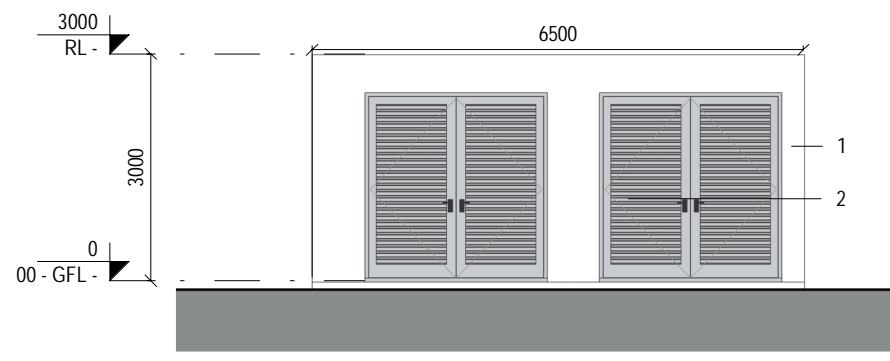

2 Front Elevation 1 : 100

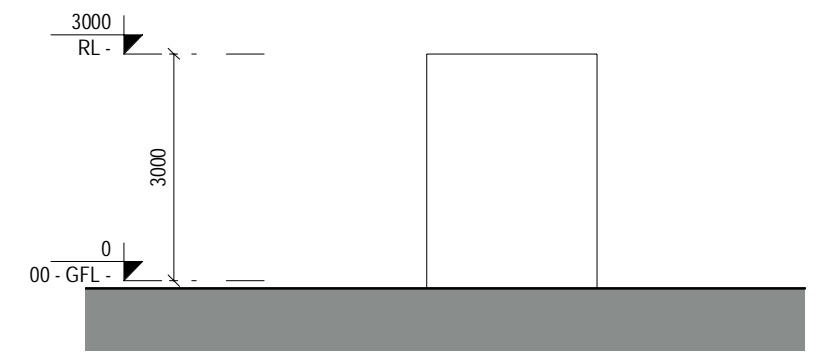

3 Side Elevation A 1 : 100

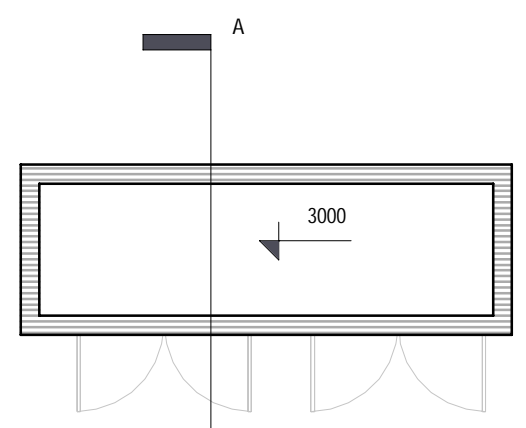

5 Roof Plan 1 : 100

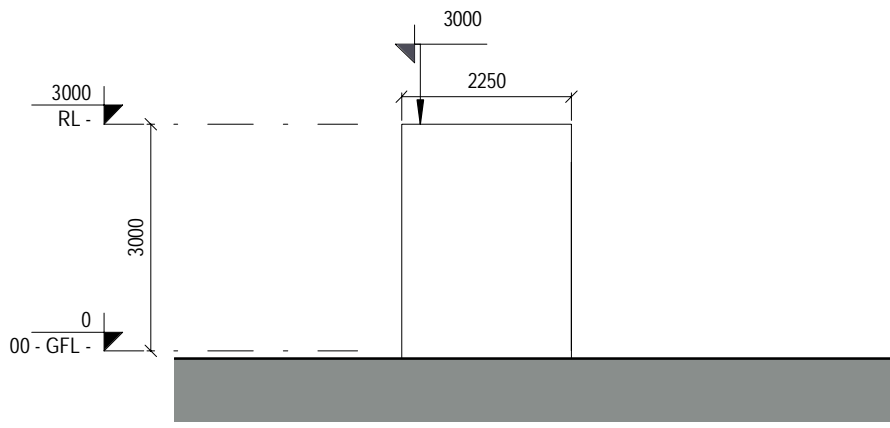

6 Side Elevation B 1 : 100

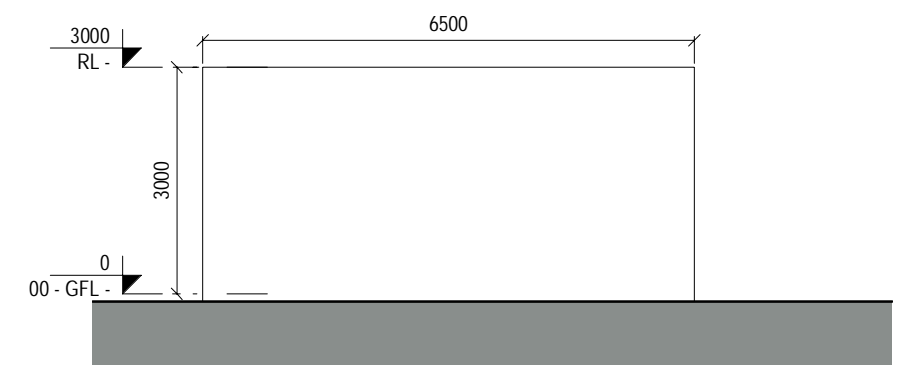

7 Rear Elevation 1 : 100

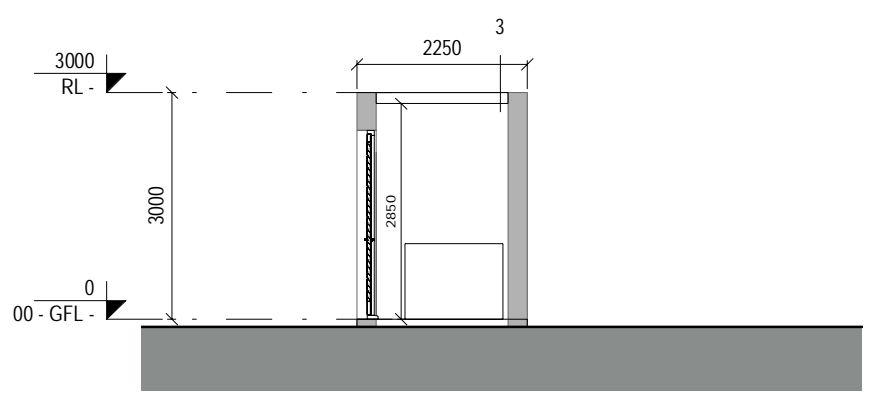

8 Section A-A 1 : 100



SHD APPLICATION

REV	DATE	DESCRIPTION	BY
1	15/05/2020	Revised Plans & Elevations	AR
2	24/06/2020	Updated Tileblock	AR
3	08/10/2020	Issued for SHD Application	AR

Note:
 *Please refer to Site Plan for Ground Floor Levels and North Point Location
 *Levels on this sheet taken from temporary benchmark at 0.0

- ← Spot Levels
- MATERIALS LEGEND**
- 1 - Sand / cement render
 - 2 - Selected Treated Steel Doors
 - 3 - Selected Trellis Timber Structure

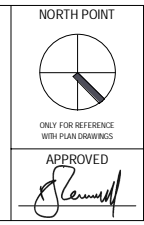

Client: BURKEWAY HOMES LTD
 Project: BEARNA RESIDENTIAL DEVELOPMENT
 Title: BIN & BICYCLE STORE - PLANS, ELEVATIONS & SECTION
 Sheet No.: 924-MDO-BS1-ZZ-DR-A-02001
 Scale as: 1 : 100 Current Rev.: 3 Project No.: 924



11 Merrion Square, Dublin 2, Ireland
 Telephone: +353 (0)1 400 4171
 info@mdo.ie | www.mdo.ie